

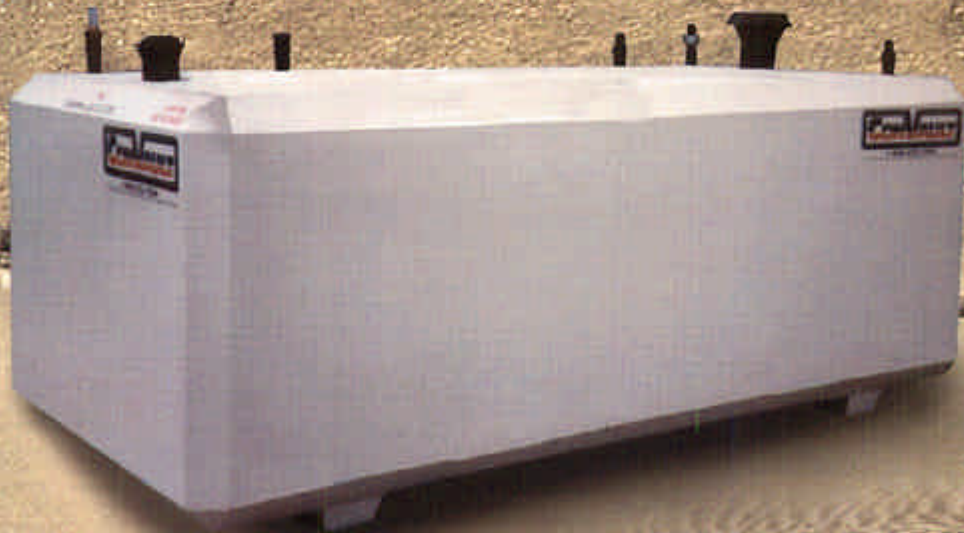

The Safest Fuel Storage on the Planet



Built to stand the test of time...

The Aboveground Solution to the Underground Problem

Interest in the preservation of our environment has prompted all levels of many governments to issue strict guidelines for the installation, operation and removal of underground storage tanks (UST's). As a result, owners and operators are faced with tedious and complicated rules and paperwork. They may also be faced with expensive upgrades, purchase of monitoring equipment, testing, and obtaining pollution liability insurance to comply with these requirements. In the event of a leak, the actual costs for soil and groundwater clean-up can be catastrophic. As aboveground storage tanks (AST's) replace UST's on a more regular basis, strict guidelines are being issued for AST's as well. ConVault's innovative Protected AST's are the proven solution for these problems.



Engineered for Safety

ConVault Protected AST's are engineered to survive in the real world. Utilizing patented manufacturing procedures, the resulting product is a tank for flammable liquids seamlessly encapsulated in six-inch thick concrete with integral secondary containment, thermal stability, vehicle impact protection, and projectile protection. The system contains no cold joints or heat transfer points on the bottom or the sides.

ConVault primary steel tanks (including spill containment basins) are fabricated in accordance with UL 142 (Seventh Edition). Each unit is pressure tested twice at the factory using ConVault patented processes to insure proper performance in the field. ConVault Protected AST's are shop-fabricated under strict quality controls in accordance with UL 2085 and ULC-S655 and ULC-S602 for Protected Tanks. Primary and secondary containment are independently tested at the plant in accordance with UL and ULC requirements.

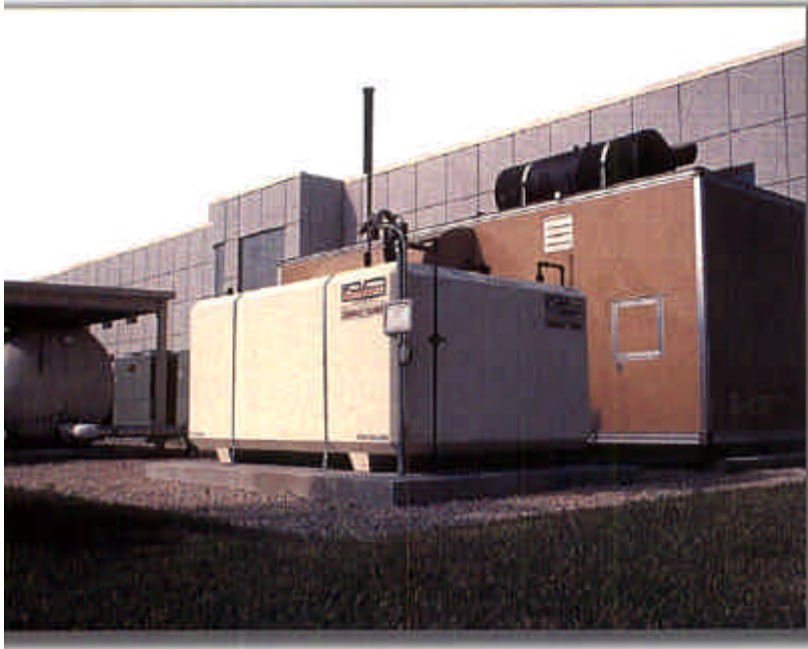

The ConVault Protected AST is listed in accordance with UL 2085, ULC-S655, and ULC-S602 Insulated/Secondary Containment for Aboveground Storage Tanks, Protected Type.

The six-inch thick (6") concrete exterior acts as a thermal mass reducing temperature variations, provides a non-corrosive, durable exterior, and provides protection for the secondary containment.

The ConVault Protected AST system has passed numerous performance tests including 2-hour liquid-pool and furnace fire tests, vehicle impact test and projectile-resistance test. Numerous real-life events have also proven the safety of the system. The end result: owners and operators of ConVault Protected AST's are provided with PEACE OF MIND.



Meets Government, Environmental and Fire Safety Regulations

Each ConVault Protected AST is exhaustively production-tested at the factory before shipment to its destination. ConVault Protected AST's meet NFPA 30, 30A and 31; UFC, BOCA, SBCCI, and International Fire Code fire safety requirements and provide grounding connections in accordance with NFPA 780. ConVault Protected AST's have been approved by environmental and fire protection officials in all states of Australia, all provinces of Canada, all states of the USA, and by government officials of the Czech Republic, England, Finland, Germany, Poland, Russia, and Slovakia.



The California Air Resources Board has certified ConVault Protected AST's for Phase I and II balanced vapor recovery, including methanol/ethanol blends. ConVault Protected AST's meet all safety requirements for primary and secondary containment, leak monitoring, spill containment and overfill protection. Specific jurisdictions may have special requirements for tank accessories. Contact your local representative for local regulations.

With the first installation in 1986, over 27,000 tanks are now in service at extremely diverse locations in over 20 different countries without a single reported system failure to-date! It is this historical performance that has been the cornerstone of regulatory comfort with the ConVault protected AST product.

Designed for Value

The ConVault Protected AST system will provide ongoing value for fuel storage. More stringent regulations are consistently on the horizon; however, with a ConVault Protected AST the need for updating is greatly reduced. ConVault operating costs are substantially lower than virtually any other AST on the market. The concrete exterior provides protection for the secondary containment, and acts as a thermal mass, reducing temperature variations (which reduces fuel vapor loss and water vapor gain), while providing a non-corrosive, durable exterior.

To meet your fuel storage needs, ConVault Protected AST's are manufactured in sizes ranging from 125 to 12,000 US gallons, or 500 to 45 000 liters (including multi-compartment options). ConVault AST's have a 20 or 30-year warranty. ConVault Protected AST's are produced at manufacturing sites around the world. The unit is shipped as a finished assembly, normally limiting the need for major on-site work to providing a concrete pad and electrical service. Although the units are intended for stationary service, in the event of changing requirements they can be moved and reinstalled. ConVault Protected AST's are thus an asset, compared to UST's or "tanks in dikes" which are usually considered a liability.



Always consult local fire and building codes before installing a ConVault Protected AST since environmental and fire safety regulations can vary between jurisdictions.

To find out more about ConVault products, please visit the web site at <http://www.convault.com>, inquire by email to info@convault.com, or call 209-632-7571 (800-222-7099 in the USA) for the ConVault representative nearest you.

US Measurements					Metric Measurements				
ConVault Size Gallons	Weight Pounds	A (Length) ft. & in.	B (Width) ft. & in.	C (Height) ft. & in.	ConVault Size Liters	Weight kg	A (Length) mm	B (Width) mm	C (Height) mm
125	6,200	4' 0.5"	4' 0.5"	3' 11"	1 000	4 000	2 350	1 150	1 100
250	8,000	7' 8"	3' 9.5"	3' 3"	2 000	6 000	3 300	1 450	1 100
500	12,000	11' 0"	4' 6"	3' 4"	4 000	9 000	3 300	1 750	1 450
1,000	18,000	11' 0"	5' 8"	4' 4"	6 000	12 000	3 400	2 400	1 500
2,000	30,000	11' 3"	8' 0"	5' 6"	8 000	13 500	3 400	2 400	1 800
3,000 LP	36,000	11' 3"	8' 0"	7' 3.5"	12 000	18 000	4 900	2 400	1 800
4,000 LP	44,000	17' 7"	8' 0"	6' 5"	16 000 LP	22 000	5 800	2 400	1 950
4,000 DW	44,000	12' 2"	8' 0"	8' 9"	16 000 HP	20 000	4 050	2 400	2 650
5,200 HP	47,000	15' 6"	8' 0"	8' 9"	20 000 LP	21 000	7 150	2 400	1 950
6,000 HP	60,000	17' 7"	8' 0"	8' 9"	20 000 HP	24 000	4 950	2 400	2 650
8,000 HP	72,000	23' 1"	8' 0"	8' 9"	22 000	25 000	5 400	2 400	2 650
10,000 HP	87,000	28' 7"	8' 0"	8' 9"	25 000	28 000	6 100	2 400	2 650
12,000 HP	101,000	34' 1"	8' 0"	8' 9"	30 000	34 000	7 250	2 400	2 650
					35 000	41 000	9 100	2 400	2 650
					45 000	46 000	10 700	2 400	2 650

Cylindrical			
Size Gallons	Weight Pounds	Diameter ft. & in.	Length ft. & in.
4,000 Cyl	46,000	9' 4.5"	11' 11"
5,200 Cyl	52,000	9' 4.5"	15' 1.5"
6,000 Cyl	60,000	9' 4.5"	17' 3"
8,000 Cyl	72,000	9' 4.5"	22' 7"
10,000 Cyl	80,000*	9' 4.5"	27' 11"
12,000 Cyl	90,000*	9' 4.5"	33' 3"

* If "lightweight Concrete is used."

Most units are also available as a split unit in several configurations.

Caution! All sizes are not available from all manufacturing plants. Shape, dimensions, and weights may vary between manufacturing plants. Other sizes not listed may be available.

Check with your local representative.

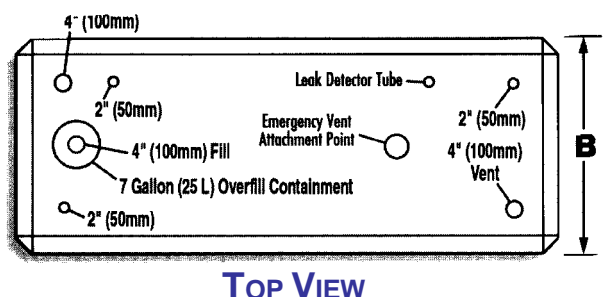
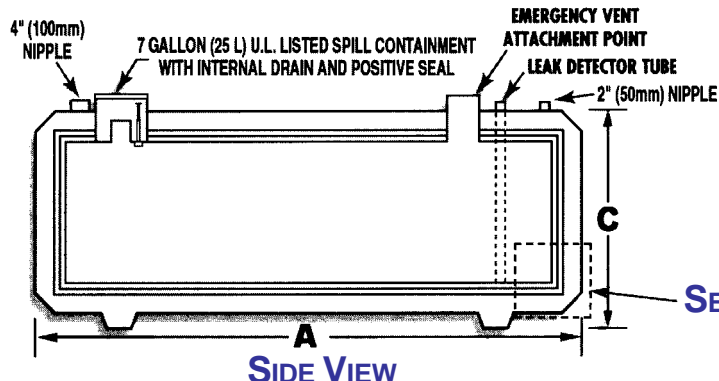

SIX STEP PROCESS

1. Steel Tank
2. 1/4" (6mm) Styrofoam Insulation
3. 30 Mil. (0.76mm) HDPE Liner
4. 1/2" (12mm) Rebar
5. 6" (105mm) Monolithic Concrete
6. Finish

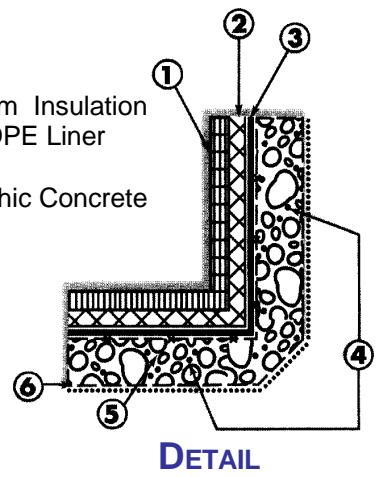

U.S. PATENT #4,826,644; #4,931,235;
 #4,934,122; #4,963,082; #4,986,436;
 #5,064,155; #5,157,888; #5,174,079;
 #5,234,191; #5,126,095

(OTHER U.S. & FOREIGN PATENTS PENDING)



CORPORATE OFFICES
 4109 ZEERING ROAD
 DENAIR, CALIFORNIA 95316

(209) 632-7571
 OR 1-800-222-7099 IN THE USA
 WWW.CONVAULT.COM
 INFO@CONVAULT.COM